



VALVOLE A SFERA per collettori Ball valves for manifolds

Art.2121

Descrizione / Description

Valvole a sfera PN 30 a passaggio totale con estremità filettata femmina e bocchettone maschio UNI ISO 228. Disponibile con farfalla rossa o blu in alluminio e leva alluminio rossa.

Full bore ball valves PN 30 with threaded female and tail male ends UNI ISO 228. Available with red or blue aluminium "T" handle and red aluminium handle.

Funzione / Function

Si adatta ad ogni tipo di impianto idraulico domestico e commerciale, applicazioni industriali ed agricole, impianti di riscaldamento ed igienico sanitari, aria compressa, olii vari, prodotti petroliferi, generalmente con ogni fluido non corrosivo.

Suitable for domestic and commercial plumbing, industrial and agricultural applications, heating and sanitary systems, pneumatic systems, oils, generally with every non aggressive fluid.



Caratteristiche Tecniche

Temperatura max di esercizio : 120 °C
 Temperatura min di esercizio : -20°C (*)
 Pressione max di esercizio : vedere tabella dimensioni
 Filettatura : femmina/maschio ISO 228

Technical Features

Maximum temperature : 120°C
 Minimum temperature : -20°C (*)
 Maximum operating pressure : see dimensional table
 Threads : female/male ISO 228

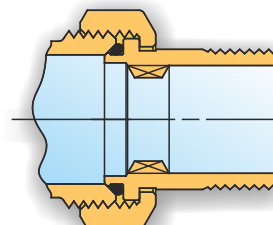

2121...

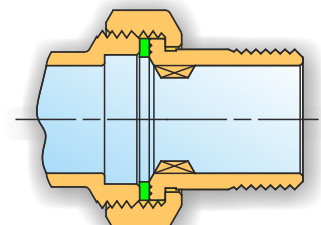

2121...CP

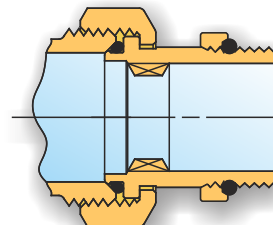

2121...R

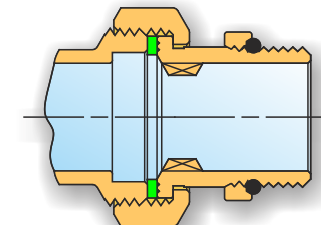

2121...CPR

(*) purché il fluido rimanga in fase liquida / provided that the fluid remains in the liquid phase

Descrizione	Materiale	Trattamento	Description	Material	Treatment
Corpo	Ottone CW617N - EN12165	Nichelato	Body	CW617N-EN12165 brass	Nickel plated
Sfera	Ottone CW617N - EN12164	Cromato	Ball	CW617N-EN12164 brass	Chromium plated
Stelo	Ottone CW617N - EN12164	-	Stem	CW617N-EN12164 brass	-
Codolo e girello	Ottone CW617N - EN12165	Nichelato	Tail and nut	CW617N-EN12165 brass	Nickel plated
Guarnizioni laterali	P.T.F.E.	-	Side washers	P.T.F.E.	-
O-rings	Gomma nitrilica NBR	-	O-ring	Nitrile rubber NBR	-
Guarnizione piana	Fibra	-	Flat gasket	Fiber	-
Leva e farfalla	Alluminio	Verniciato	Handle & Butterfly	Aluminium	Painted
Dado	Acciaio	Zincato	Nut	Steel	Zinc plated

Certificazioni Certifications





Dimensioni Dimensions

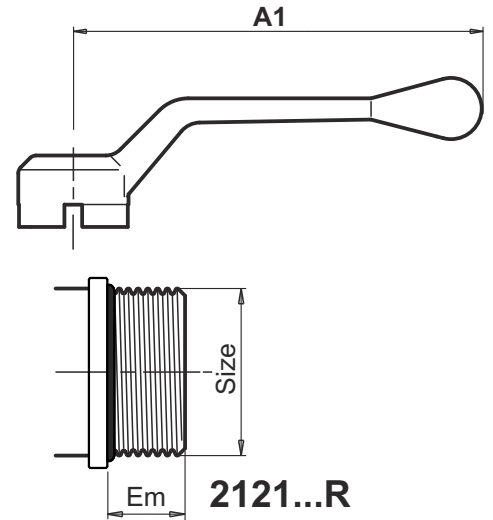
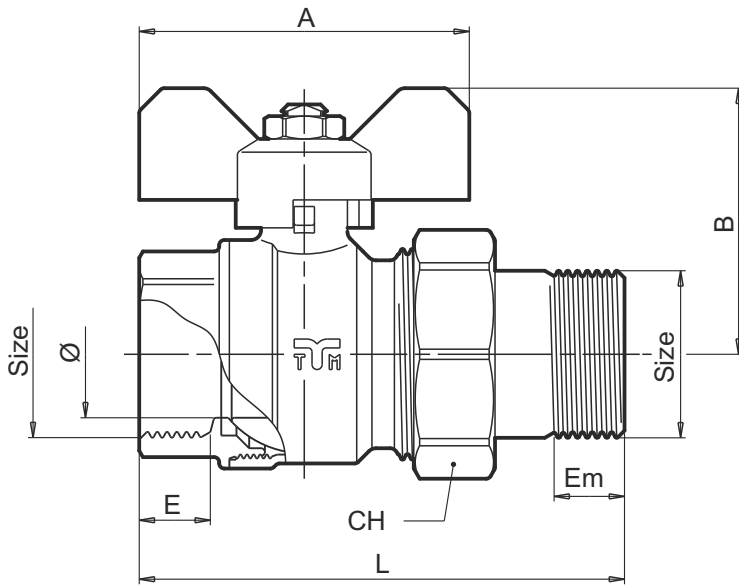

Size	1/2"	3/4"	1"	1"1/4	1"1/2*
Ø (DN)	15	20	25	32	40
A	50	50	65	65	-
A1	-	-	-	-	140
B	40	43,5	52,5	57,5	79
CH	30	37	46	52	66
E	13,5	14,5	14	15	15
Em	10	12	14	15	16
L	72,5	83	95,5	111,5	123
PN	30	30	30	25	25
PN aria compressa pneumatic systems	20	20	20	20	20

* solo versione "CP"
* only "CP" version



Diagramma pressione / temperatura
Pressure / temperature diagram



Diagramma portata/perdita di carico
Flow/pressure drop diagram



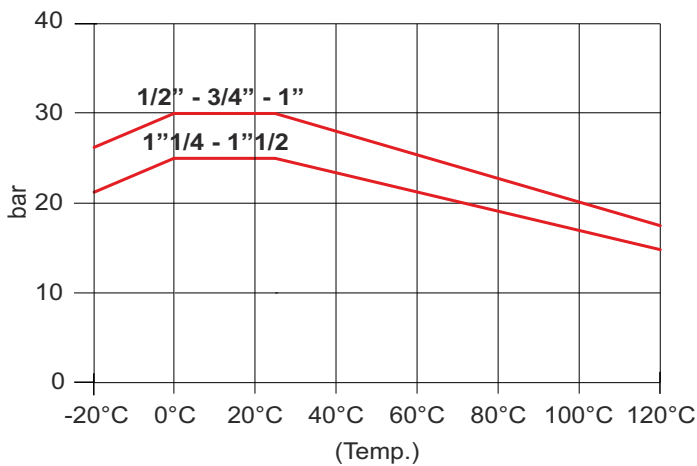
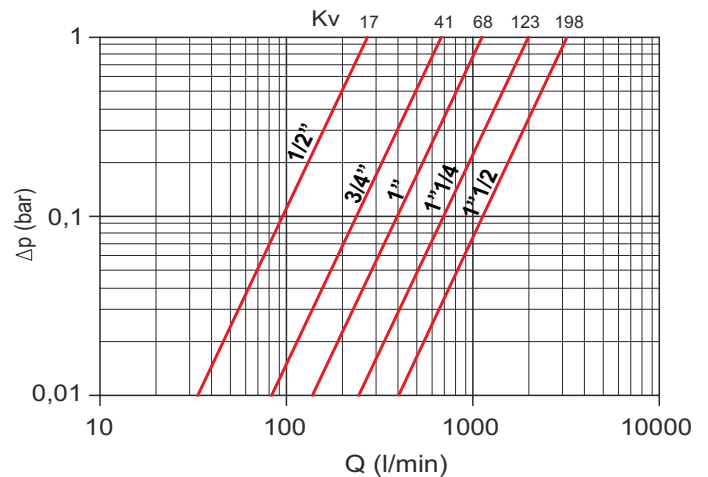

Istruzioni per l'installazione Installation instructions

Le valvole possono essere montate in qualsiasi posizione (orizzontale, verticale, ...) purchè siano visibili, accessibili e le operazioni di manovra possano essere facilmente eseguite fino alla completa chiusura e/o apertura.

Salvo diversamente indicato la chiusura della valvola avviene in senso orario e l'apertura in senso anti-orario.

La direzione di montaggio della valvola rispetto al flusso del circuito è indifferente se non diversamente specificato con l'apposizione di specifiche marcature (generalmente frecce) sul corpo valvola.

L'impianto deve essere progettato e realizzato in modo tale da evitare sollecitazioni tali da danneggiare la valvola ed impedirne la corretta tenuta ed il buon funzionamento.

Le operazioni di collegamento tra la valvola e la raccorderia di connessione all'impianto devono essere eseguite con attrezzature idonee. La coppia di serraggio deve essere tale da garantire la corretta tenuta senza arrecare danneggiamenti alla valvola od ai raccordi.

Ad installazione completata è necessario eseguire la verifica delle tenute secondo quanto specificato dalle norme tecniche e/o dalle leggi vigenti nel paese di utilizzo.

La valvola non va tenuta in posizione intermedia per lunghi periodi onde evitare danneggiamenti degli organi di tenuta della valvola stessa.

In caso di lunga inattività della valvola è possibile che la manovrabilità risulti difficile pertanto si rende necessario l'utilizzo di "leve lunghe" per facilitarne l'apertura e/o chiusura.

Per mantenere la valvola ed i relativi organi di tenuta in buone condizioni è suggerito installare un filtro per la raccolta di eventuali impurità a monte della valvola.

Tiemme Raccorderie SpA declina ogni responsabilità in caso di guasti e/o incidenti qualora l'installazione non sia stata realizzata in conformità con le norme tecniche e scientifiche in vigore ed in conformità a manuali, cataloghi e/o relative disposizioni tecniche indicate da Tiemme Raccorderie SpA.

Per qualsiasi ulteriore informazione rivolgersi ai rivenditori autorizzati o direttamente a TIEMME SpA.

The valves can be installed in any position (horizontal, vertical, ...) provided that shall be placed in visible and accessible position and the open/close operations shall be easily and completely done.

Otherwise stated to close the valve the handle shall be turned clockwise, counterclockwise to open it.

Otherwise stated by specific marks on the valve body (arrows,...) there is no valve flow direction.

The system shall be designed and realised in order to avoid any stress that could damage the valve and could compromise the sealing and the correct working of the valve.

All installation operations shall be done using properly tooling. The tightenings shall be such as to guarantee the sealing but without make any damage to the valve or fittings.

Once the installation have been completed is necessary to verify the sealings according to technical specifications and/or what required by the country of installation.

The valve should not be kept in intermediate position for a long period of time in order to avoid any damages of the valve sealings.

If the valve have not been used for a long period of time it may be difficult to operate therefore it will be necessary to use a "long lever".

To kept the valve and sealings in good conditions it is suggested to place a filter upstream in order to stop impurity.

Tiemme Raccorderie SpA decline any responsibility in case of damages and/or accidents when the installation is not done in conformity with technical and scientific rules in force and in conformity with manuals, catalogues and/or technical documentation written by Tiemme Raccorderie SpA.

For any further information please refer to your local dealer or directly to TIEMME S.p.A.